



Music Thing Modular Turing Machine Mkii version

PLEASE DO NOT LINK TO OR REDISTRIBUTE THIS DOCUMENT WITHOUT PERMISSION FROM THONK

For the most recent version of this document please visit –
<https://www.thonk.co.uk/shop/turingmkii/>

Refer also to the Music Thing documentation here –
<https://github.com/TomWhitwell/TuringMachine/>

For all technical support please create a Github account and log an issue here –
<https://github.com/TomWhitwell/TuringMachine/issues>

Chat about the build here –
<https://www.muffwiggler.com/forum/viewtopic.php?t=159116>

All Thonk kits are sold under our standard Terms and Conditions –
<http://www.thonk.co.uk/faq/>



DIY INSTRUCTIONS

This document gives detailed instructions that assume you have purchased a complete Turing Machine kit from www.thonk.co.uk after April 2016, it also assumes no previous knowledge of electronics.

To learn to solder try <https://www.youtube.com/watch?v=lpkkfK937mU> and the **Adafruit guide to excellent soldering** – <http://bit.ly/1I77tF4>

Watch and understand that whole YouTube video! If you're not achieving the results shown in the video then you need to buy new tools or seek advice.

You will not end up with a working unit otherwise.

TOOLS REQUIRED

Soldering iron, snipe nose pliers, wire strippers, small flat head screwdriver and diagonal cutters AKA snips AKA side-cutters. A Digital Multimeter is always helpful for checking for bad solder joints and continuity. Thonk sell a range of inexpensive tools here – <http://bit.ly/1jqF3n>



SOLDER JOINTS

Your solder joints should look like those shown as 'OK' below, they should have that neat conical shape on **BOTH sides of the PCB**. If they don't look the same on both sides then stop! Work out why from the soldering guides linked and don't continue until you are getting those results.

This isn't about perfectionism, you are very likely to end up with a destroyed, damaged or defective unit if you're not hitting that standard.

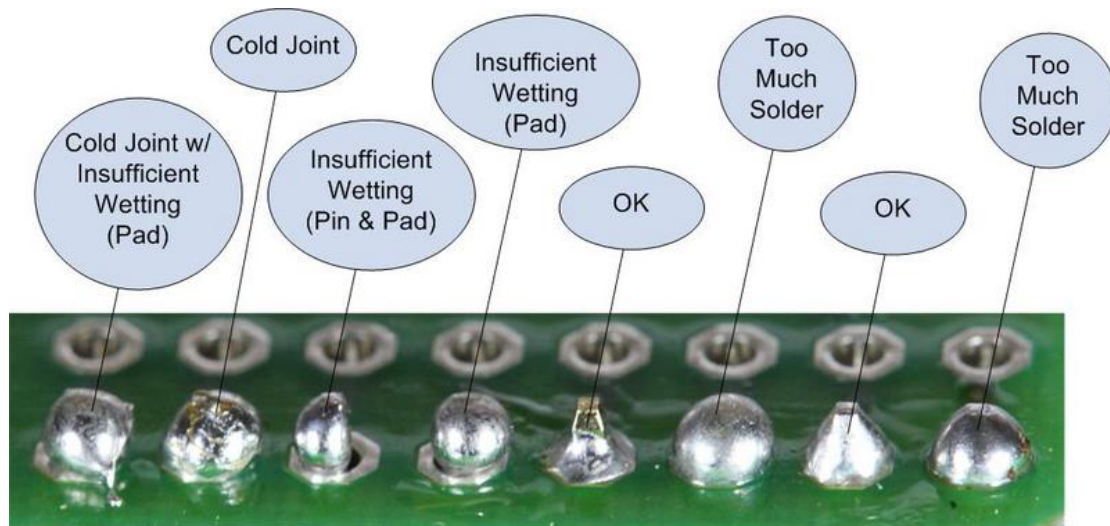

This photo is from the **Adafruit guide to excellent soldering** - <http://bit.ly/1I77tF4> and is reproduced under an Attribution-Sharealike creative commons license - <http://creativecommons.org/licenses/by-sa/3.0/>

If your kit is in a paper bag as pictured, then proceed using this build document.

If your kit is packaged in a plastic bag then use build document version 1.01 instead - found here: www.thonk.co.uk/wp-content/uploads/Documents/turing2016





TURING MACHINE BUILD INSTRUCTIONS

1.

To start with we advise emptying the Resistor bag and Capacitors + Diodes bag each into separate bowls or containers making it easier to find parts.

This document has hi-res images.
ZOOM IN for a closer look

2.

Start with this PCB which we will call the **IC PCB**.

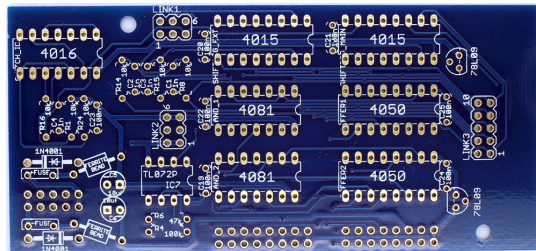

3.

First, using the coloured chart provided, locate the **10K** resistors and solder six of them into positions **R1, R8, R14, R15, R16 & R24** as shown.

Use the resistor colour bands and quantities on the chart to identify the different values.

You should have four **10K** resistors left over for the other PCB.

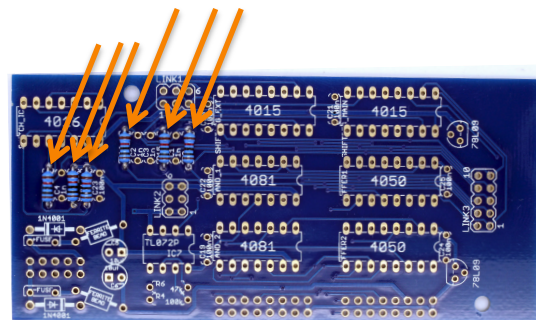

Note! Make sure your solder joints look like the joints shown on page 2, with solder coming through on BOTH sides of the PCB.

If you're not achieving this quality of solder joint then consider changing your iron settings or get a new soldering iron tip, or a better solder brand.



4.

Solder the single **47K** resistor into position **R6** as shown

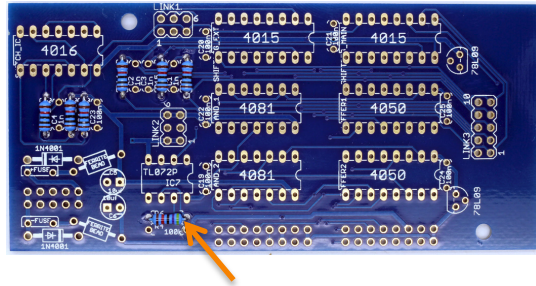

5.

Solder the single **100K** resistor into position **R4** as shown

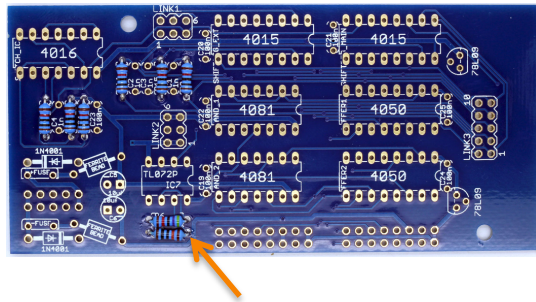

6.

Locate the two 1N4001 diodes in the bag labelled 'Capacitors + Diodes' and solder into the positions as shown.

NOTE! Orientation of this part is vital, the module will not work if they are the wrong way round.

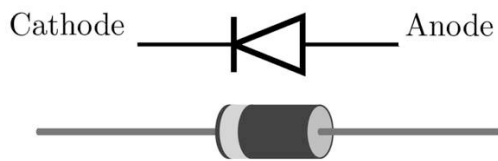

www.thonk.co.uk

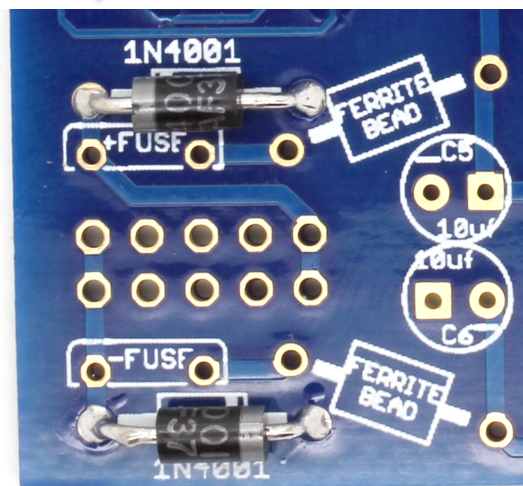
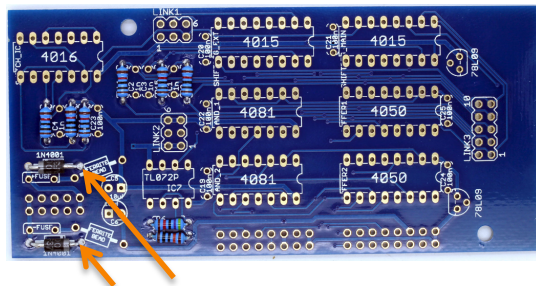



7.

Solder the two **Ferrite Beads** into place as shown.

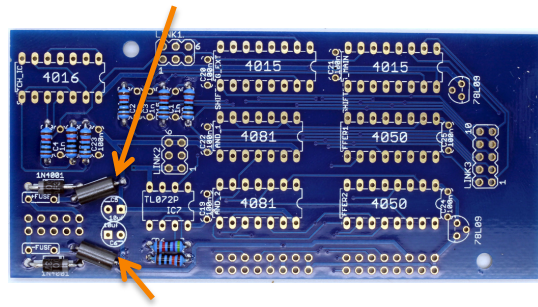

8.

From the mech bag next find the eight IC sockets and solder into place. Make sure the notches in the sockets match the notches on the silkscreen.

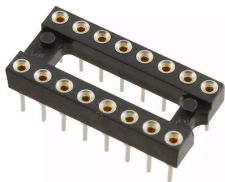

3 x 14 pin 4 x 16 pin

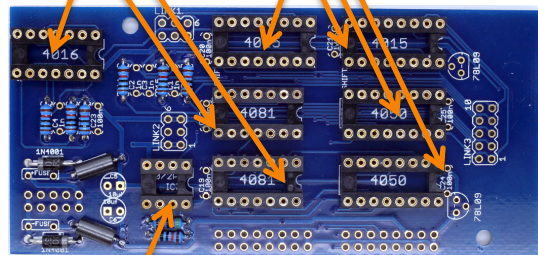

1 x 8 pin

9.

Next find the six 1nF Capacitors and solder four of them into positions C1, C2, C3, C4.

These capacitors are marked '102'

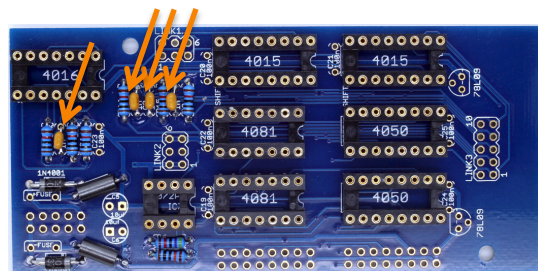
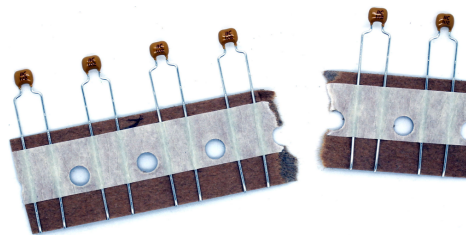



10.

Next identify the twelve 100nF capacitors and solder seven of them into positions C19, C20, C21, C22, C23, C24 & C25

These capacitors are marked '104'

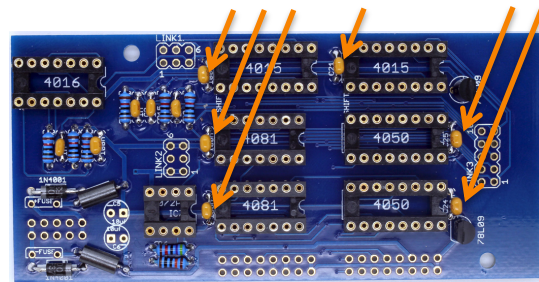
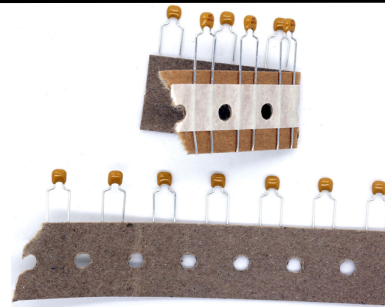

11.

From the separate IC bag, identify the two **78L09** voltage regulators. Make sure you check the codes correctly!

Do not mistake them for the single **TL431** or single **2N3904** included which look very similar. With a magnifying glass you will see **78L09** printed on the flat face.

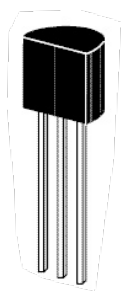

Solder into the positions shown.

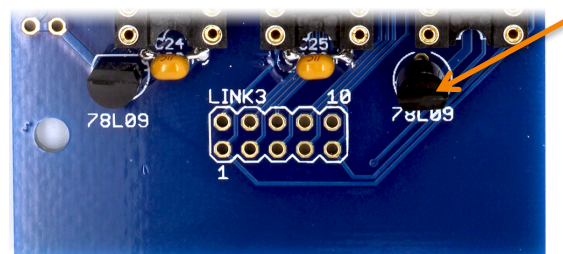
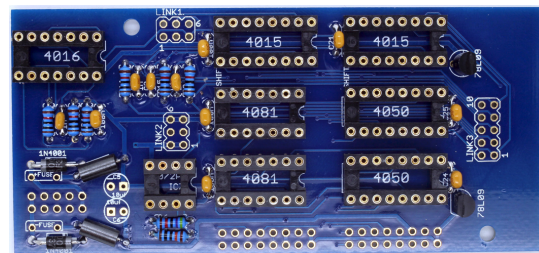

NOTE! Ensure the flat faces on the components match the flat faces on the PCB silkscreen. You need to bend the middle lead of the component backwards to achieve this to go through the centre hole. Orientation is vital.



12.

Next solder the two Electrolytic 10uF capacitors into positions **C5** and **C6**.

NOTE! The orientation is vital, the shorter lead on the component should go to the circular pad marked with a minus '-' on the PCB. Note the component has a grey stripe on the cylindrical body on the minus side.

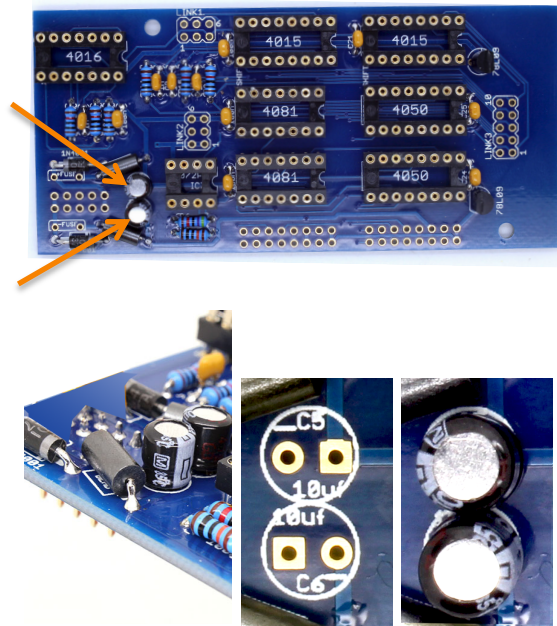

13.

Solder the three female dual row sockets into place as shown. There are two six pin sockets and one ten pin socket. Make sure they are soldered flat against the PCB.

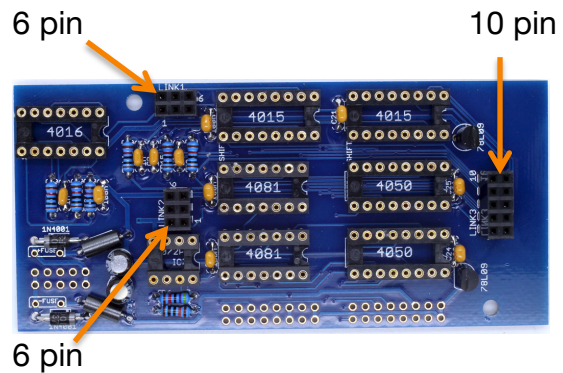

14.

Now flip the board over and solder the two 16 pin male headers and one ten pin header.

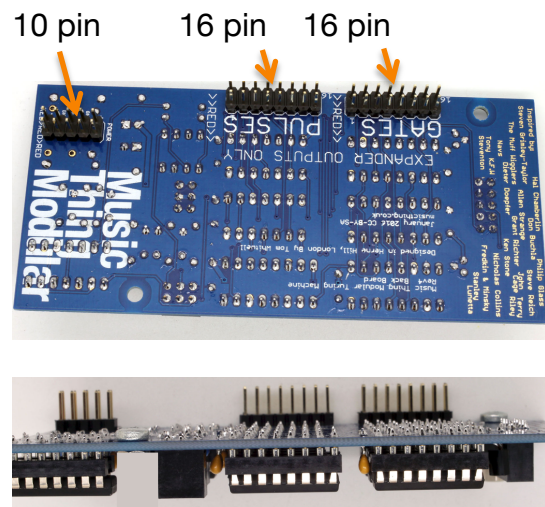
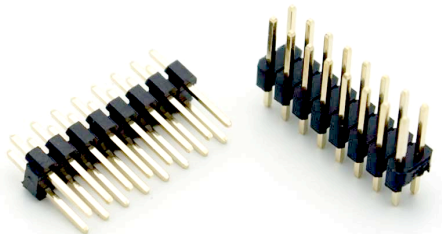



15.

Identify the two fuses and solder into place as shown. The orientation doesn't matter, but the larger fuse **MUST** go into the '+ Fuse' position.

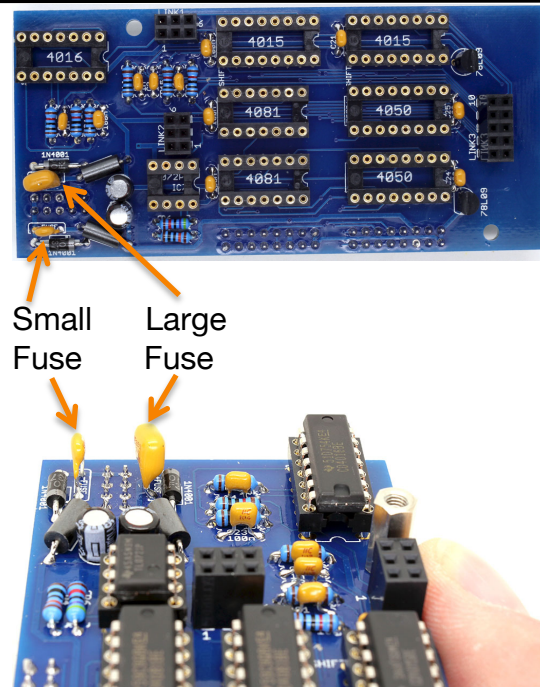

16.

Next you will place the eight IC's required on this PCB as shown.

NOTE – Orientation is vital!

NOTE! You will need to bend the pins on the IC inwards slightly so they are at 90 degrees to the body of the chip. They will come slightly splayed out. This can be done safely by clamping the 4 pins in a pair of pliers (not the cutting edge near the pivot joint though!) and very gently bending inwards together. Repeat for the other side.

NOTE! BOARD IS FLIPPED 180 DEG IN THIS IMAGE

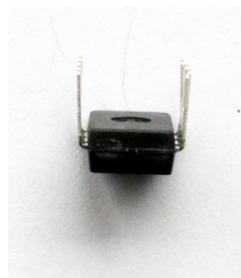
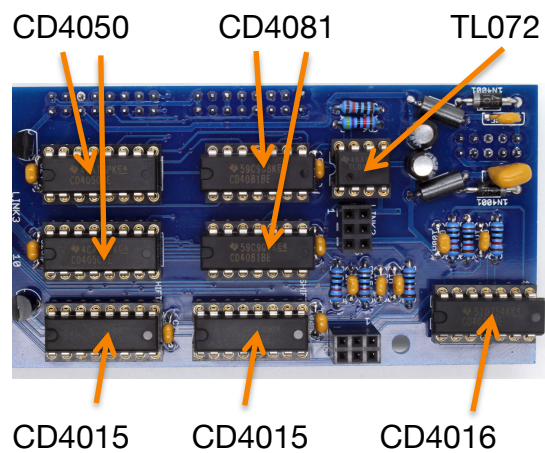



17.

Take the two hex posts and screw into the top of the board like shown with two of the screws provided.

You are now finished with the back board and are just over half-way through the build.

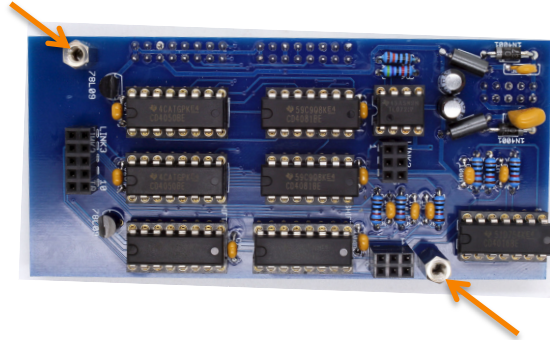

NOTE! Is it late? Go to bed and do the rest tomorrow, you have a far better chance of building a functioning module that way. Best soldering advice you'll ever get!





18.

Let's move onto the other PCB, which we call the 'Jack PCB'

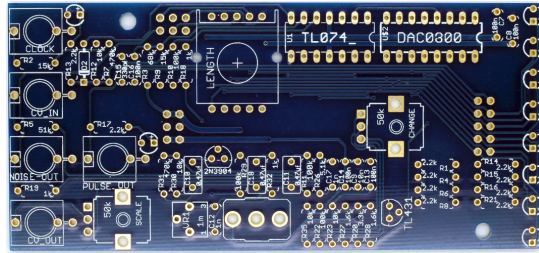

19.

Identify the single **1N4148** diode and solder into the position show. Note the black line on the body of the Diode should match the white line on the silkscreen.

NOTE! Orientation of this component is vital.

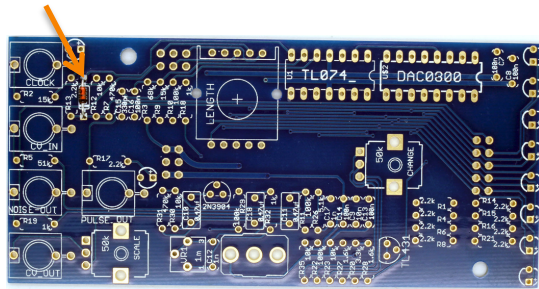

20.

Solder the three **1K** resistors into positions **R18**, **R19** and **R32** as shown.

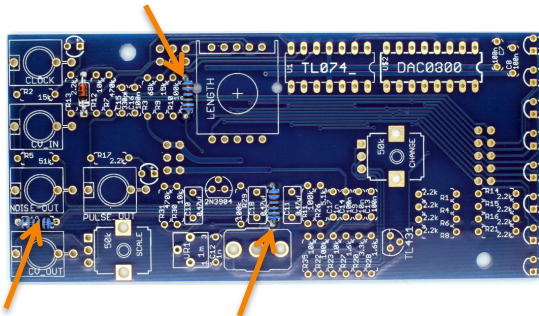

21.

Solder the two **1.6K** resistors into positions **R27** and **R28** as shown.

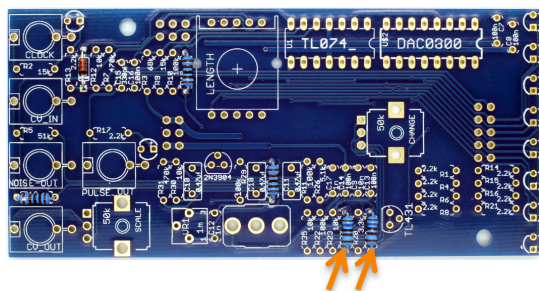



22.

Note: Due to changes in the supply of the LED's used for this design, your kit will contain 10x of either **3.9K OR 2.2K** resistors and the correct LED's to match.

The positions for these resistors on the PCB will be labelled with the values 2.2K as well as the numbered designators, however whichever of the two values your kit is provided with will be correct.

From Mid-May 2024 all new Think kits now have 3.9K included.

Solder these resistors into positions **R1, R4, R6, R8, R13, R14, R15, R16, R17 & R21.**

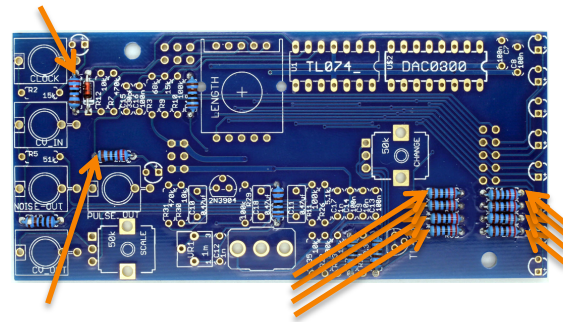

23.

Solder the single **3.3K** resistor into position **R20** as shown.

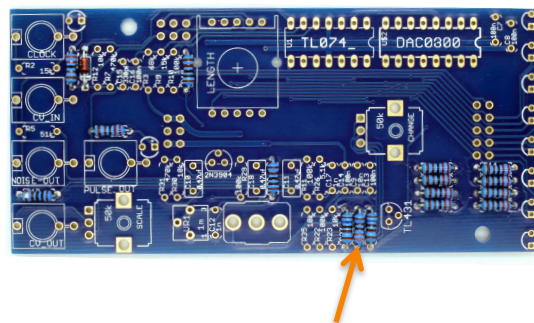

24.

Solder the single **5.1K** resistor into position **R26** as shown.

Note: do not confuse with the 51K resistor, check the colour bands carefully.

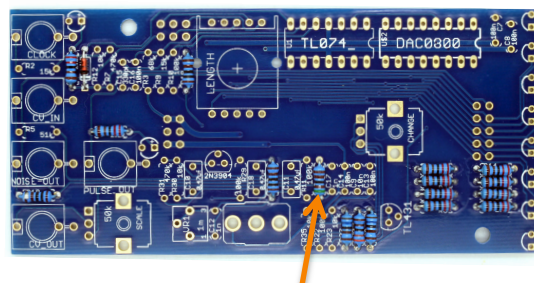



25.

Solder the two **15K** resistors into positions **R2** and **R9** as shown.

Solder the four remaining **10K** resistors into positions **R12**, **R23**, **R30** and **R35** as shown.

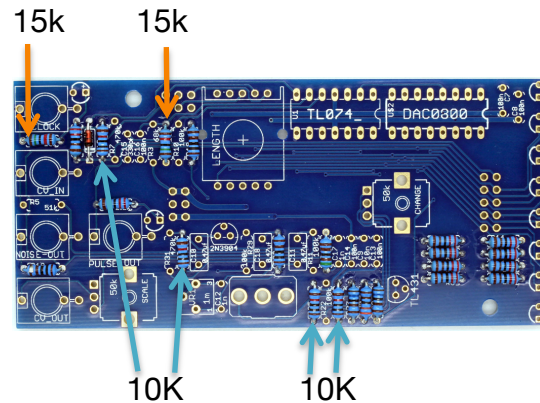

26.

Solder the single **68K** resistor into position **R3** as shown.

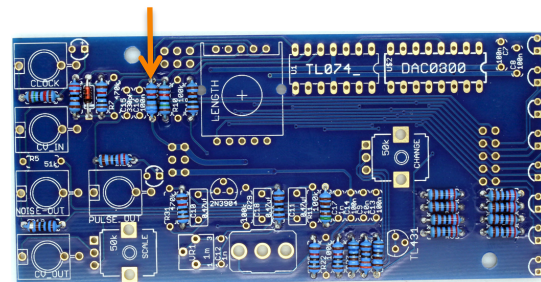

27.

Solder the single **51K** resistor into position **R5** as shown.

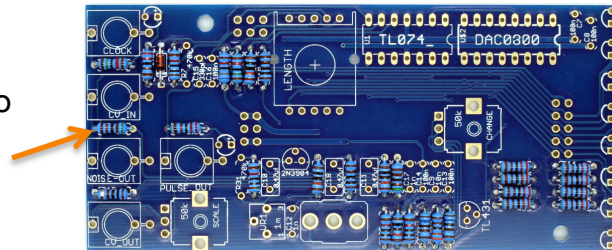

28.

Solder the four remaining **100K** resistors into positions **R10**, **R11**, **R22** and **R29** as shown.

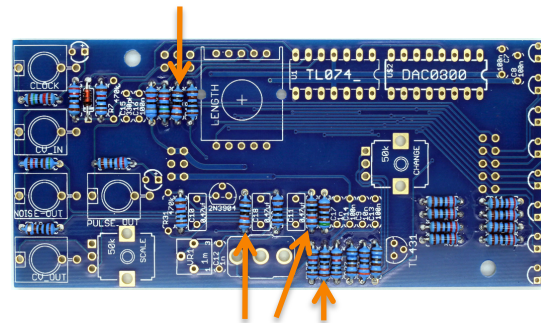

29.

Solder the two **470K** resistors into positions **R7** and **R31** as shown.

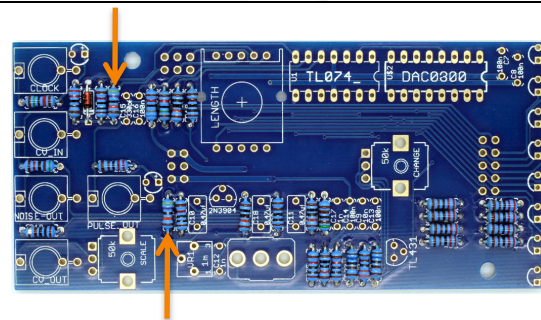



30.

Solder the two remaining **IC Sockets** into the positions shown. Make sure the notches in the sockets match the notches on the silkscreen.

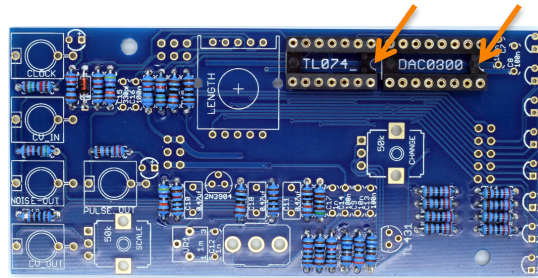

31.

Find the two remaining 1n capacitors (marked '102') and solder into positions **C12** and **C17** as shown.

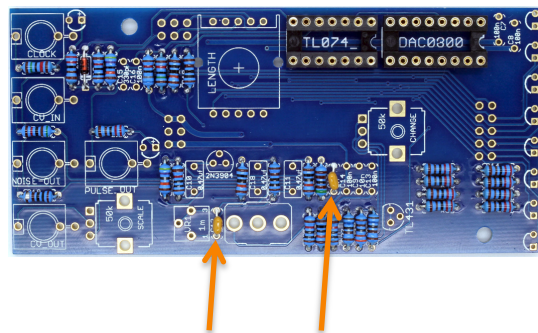
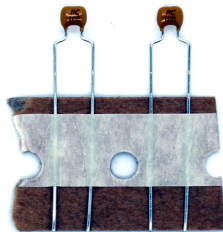

32.

Next solder the single 10n capacitor (marked '103') into position **C9** as shown.

Then solder the remaining five 100n capacitors (marked '104') into position **C7, C8, C13, C14 & C16** as shown.

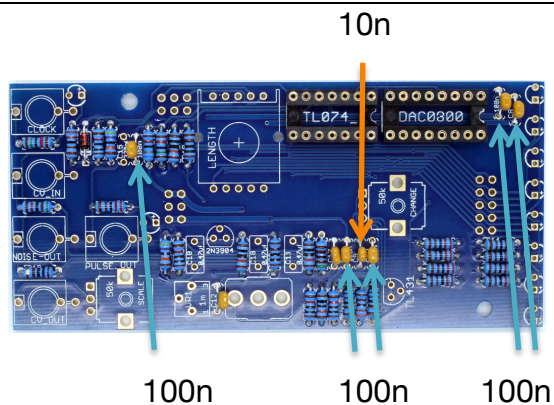

33.

Solder the single blue trimmer into position as shown. Make sure it is flush to the surface on the PCB.

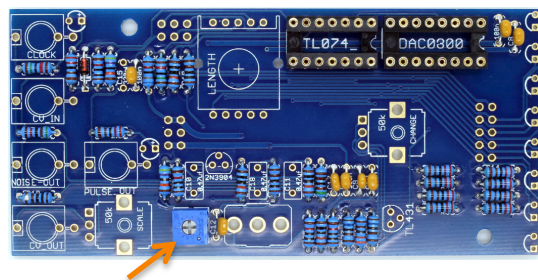



34.

Next identify the single **2N3904** transistor. Make sure you check the codes correctly! Do not mistake it for the **TL431**



Solder into the position shown.

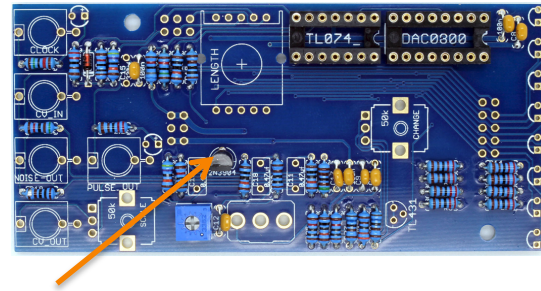

NOTE! Ensure the flat face on the component matches the flat face on the PCB silkscreen. You need to bend the middle lead of the component backwards to achieve this to go through the centre hole. Orientation is vital.

35.

Next identify the single **TL431** transistor and solder into the position shown.

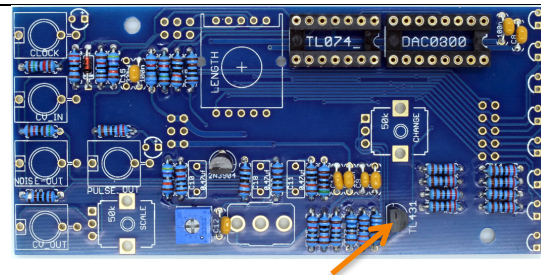
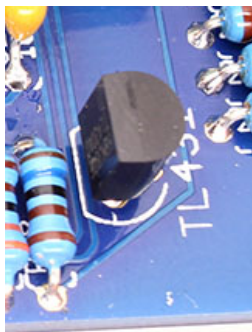

NOTE! Ensure the flat face on the component matches the flat face on the PCB silkscreen. You need to bend the middle lead of the component backwards to achieve this to go through the centre hole. Orientation is vital.

36.

Solder the three **0.47uF** film box caps into positions **C10**, **C11** and **C18** as shown.

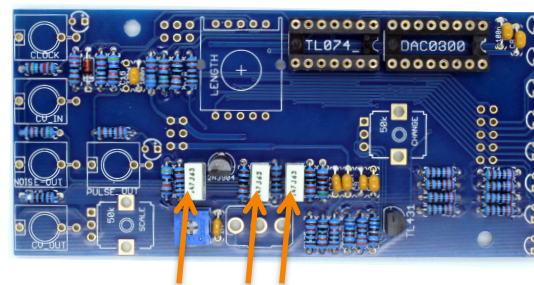



37.

Solder the single **330pF** cap into position **C15** as shown.

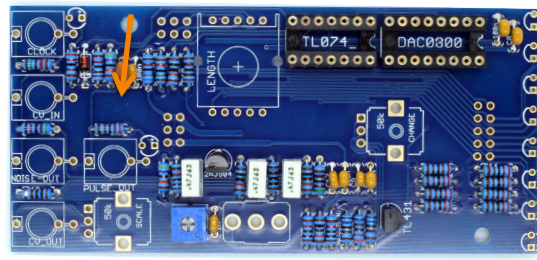

38.

FLIP THE PCB OVER and solder the three male double row pin headers into position as shown. Ensure these are soldered flush to the PCB surface.

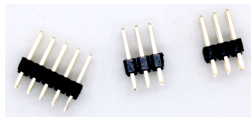
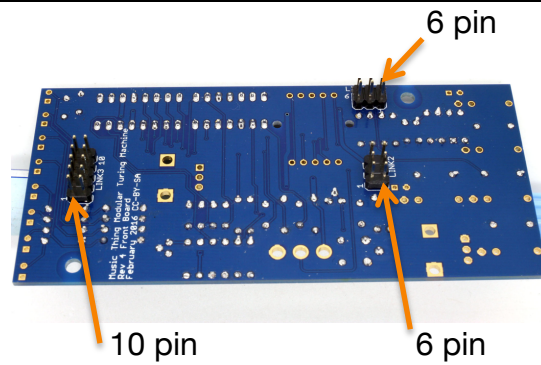

39.

Identify the following panel parts:

ROTARY SWITCH x1
(LENGTH)

TOGGLE SWITCH x1
(WRITE)



Remove all washers and nuts from the red switch. Only use one nut and discard the rest.

B50K Pot x1
(CHANGE)

B50K Pot x1
(SCALE)

THONKICONN
JACK SOCKETS x5

RED LED's x10



If your pots have the small anti-rotation tag on then break them off first.

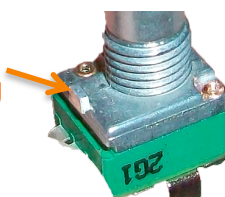



40.

DO NOT SOLDER YET

Position all the parts in section 42. as shown on the PCB but **DO NOT SOLDER YET!**

NOTE! The longer lead of the LED MUST go to the pad marked with a + on the PCB silkscreen.

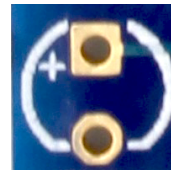
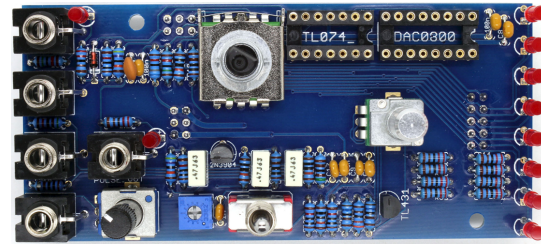

41.

If you want to fit the flat head LEDs so they fit flush to the panel then apply masking tape over the 10 LED holes in the front panel.

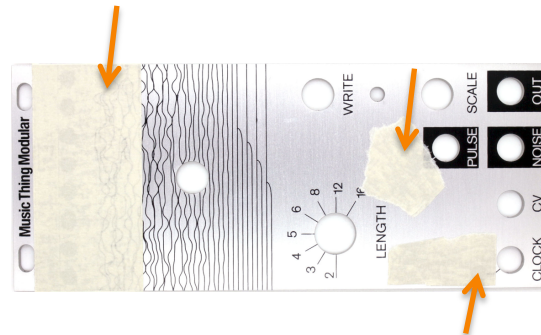

42.

Now position the panel onto the PCB, making sure that the jacks, pots and switches are all aligned correctly, and the panel is sitting completely parallel to the PCB and flush to the tops of the components.

Secure into place by hand tightening the Pot and switch nuts and a couple of jack nuts.

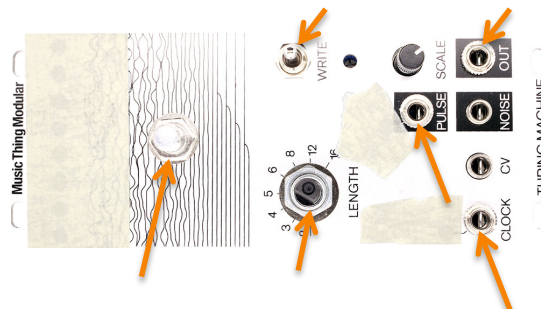



43.

Before you solder you're going to push all ten LEDs into the holes into the panel, so the flat heads are sticking to the masking tape and held nicely flush with the surface of the panel.

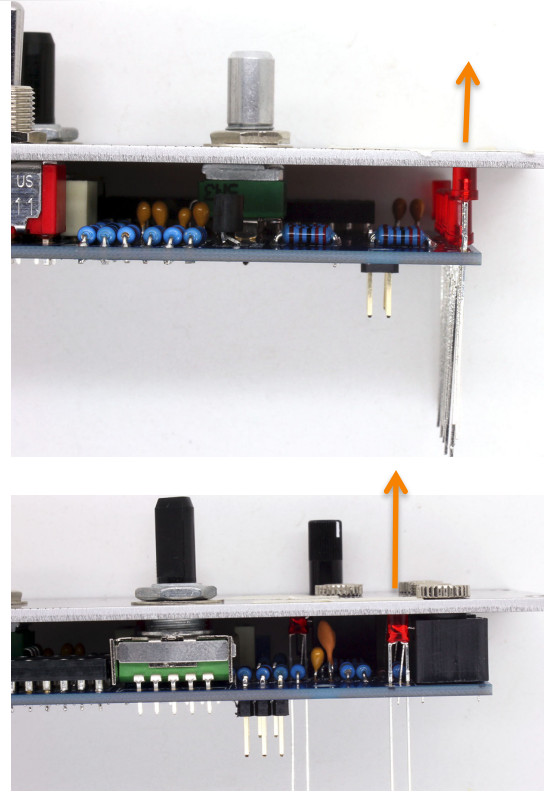

44.

Now with the panel holding everything correctly aligned finally solder all the pots, switches, jacks and LEDs.

Double check all solder joints! There are **55** to do all at once.

You are now finished soldering. Shut off your iron!

Green Rotary switch – 7 solder joints

Red Toggle switch – 3 solder joints

Green Pot – 5 solder joints

Blue Pot – 5 solder joints

LEDs – 20 solder joints in total

Jacks – 15 solder joints in total



45.

Next you will remove the metal panel and fit the two remaining IC's onto this PCB as shown.

NOTE – Orientation is vital!

NOTE! You will need to bend the pins on the IC inwards slightly so they are at 90 degrees to the body of the chip. This can be done safely by clamping the 4 pins in a pair of pliers (not the cutting edge near the pivot joint though!) and very gently bending inwards together. Repeat for the other side.

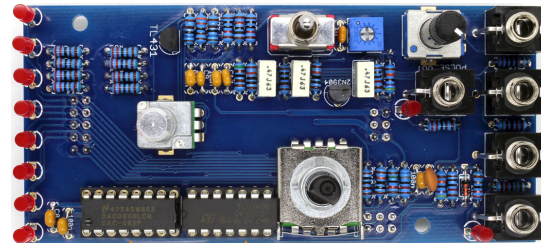

DAC0800 TL074

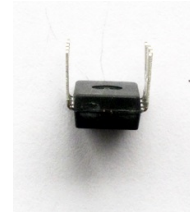
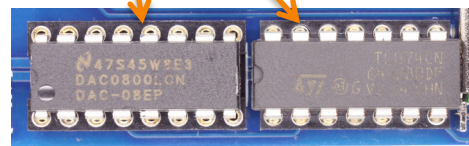

46.

Next mate the two boards together as shown. Secure with two of the remaining M3 screws

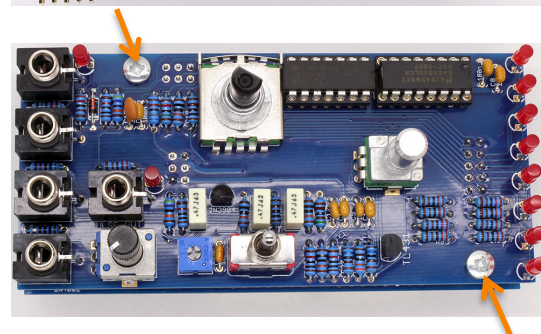
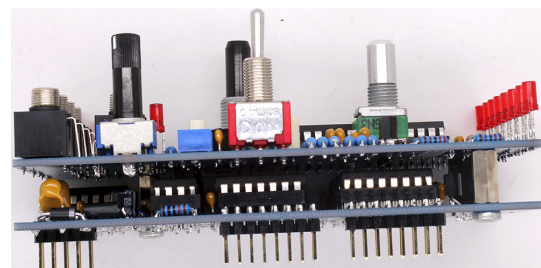
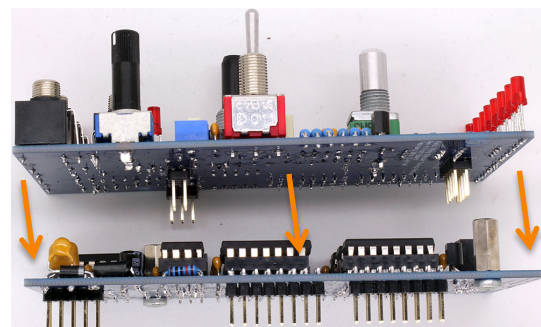



47.

Now finally put the metal panel onto the top PCB and secure all the remaining nuts and washers.

Put the two knobs on.



48.

Attach the power cable like so with the red stripe down, at the end of the power connector indicated on the PCB with 'RED'

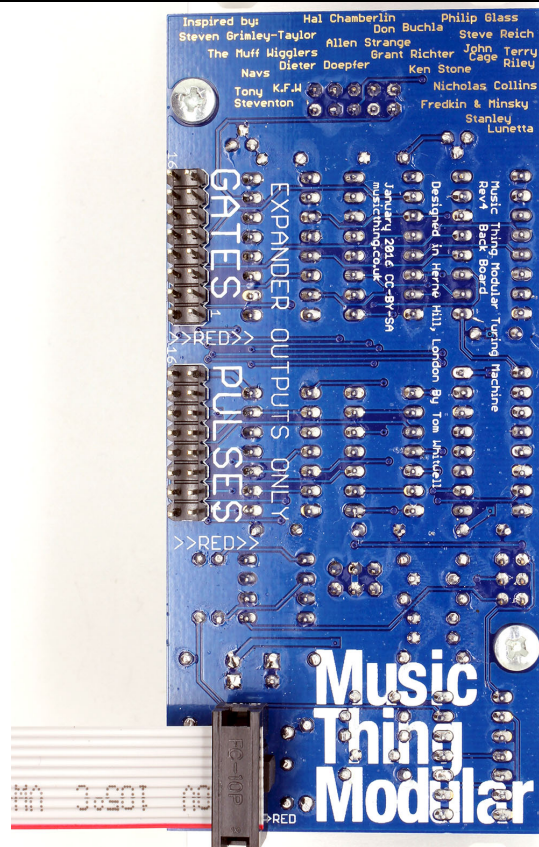



49.

You are now ready to power up and calibrate.

Complete your setup by following this video - <https://vimeo.com/163160088>

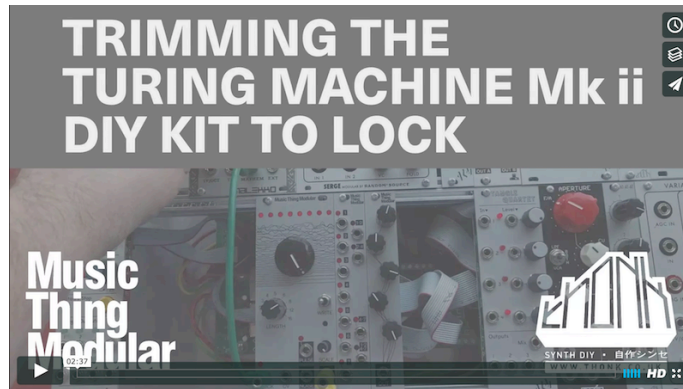

For all technical support please create a Github account and log an issue here - <https://github.com/TomWhitwell/TuringMachine/issues>

Chat about the build here –
<https://www.muffwiggler.com/forum/viewtopic.php?t=159116>