

User Manual V1.0

Introduction

Gloop is an experimental eurorack looper. It allows you to record loops (with overdub), and playback with 4 simultaneous play heads. Each play head can be at a different part of the loop, playing at a different speed/pitch, direction and volume. Each play head can also be playing a different area, or sub-loop of the main loop. This can allow you to trim the loop size, play different sections of the main loop with the different play heads or create granular style effects.

All 4 play heads are constantly playing, but only the 'Active Play Head' can be modified by the panel controls. The playheads can be combined into a single mix and routed to two separate channels, A and B.

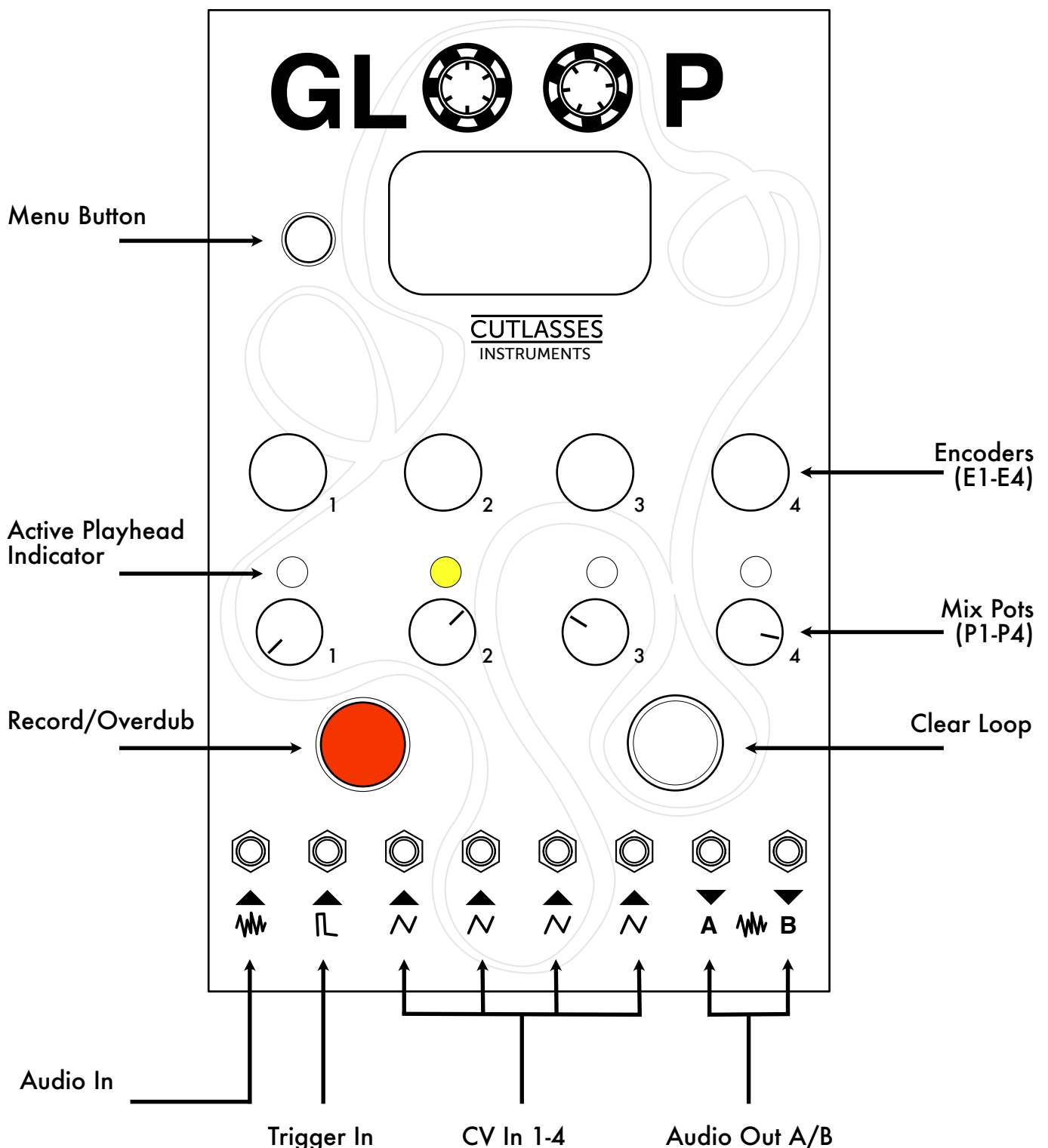

Technical Specs

Current draw - +12V 165mA, -12V 35mA Max

CV inputs - -5V to 5V (larger signals will be clamped)

Trigger input - >3V required to trigger

Audio: 48Khz 24-bit digital audio, 2 minute maximum loop length

Controls

Menu Button

Press to cycle through menus, see *Menus*.

Encoders 1-4

Each encoder has a switch so can be turned and clicked. The purpose of the encoders changes depending on which screen you are in.

Potentiometers 1-4

The potentiometers, or 'pots', are used to adjust the volume of each play head.

Record/Overdub Button

Press once to start recording and press again to end the loop. If overdub is enabled, subsequent presses of the button will start and stop overdubbing. The screen will flash when recording.

Clear Loop Button

Hold for 2 seconds to clear the current loop.

Audio In

Connect audio to the module. Gloop cannot generate sound without having audio input.

Trigger Input

The trigger input is equivalent to pressing the record button. Use a trigger voltage to get the start and end points in time.

CV In 1-4

Connect CV to modulate Gloop. See *CV Targets* for details on how to configure it.

Audio Out A/B

Two channels of audio out. Play heads can output to either of these, or to both.

Quick Start

Before you dig into the details of Gloop's functionality you might just want to start patching and playing. One of the defining elements of Gloop is its multiple play heads, so let's get started by learning how to play with them.

1. Turn all pots fully anti-clockwise (muting all play heads).
2. Plug in a modular level audio source into Audio In.
3. Connect Audio Out A to your system output.

4. To start recording the loop, press the red button, to end recording, press it again.
5. The waveform of the loop will appear on the screen.
6. Turn the first pot clockwise and you will hear the recorded loop.
7. Rotate Encoder 2, this will reduce the size of active loop. You will see the > > loop indicators move inwards.
8. Rotate Encoder 1, this will change the position of the loop. You will see and hear Gloop playing a smaller sub-section of the original loop.
9. Rotate Encoder 4, you will hear the pitch of the loop change.
10. Press Encoder 1 to change the active play head. You will see [H1] change to [H2], indicating you are now controlling play head 2.
11. Rotate Pot 2 clockwise, you will hear play head 2 mixed with play head 1.
12. You can now blend together all of the play heads, by pressing Encoder 1 to cycle through the play heads, and mixing them together with the pots. Experiment with changing the size, position, and pitch of each loop.

Main Screen

This is the screen you will see when you start up Gloop. This is where you will see the waveform of the recorded loop and edit the sub-loop sections for every play head.

The writing in [] from left to right correspond to the 4 encoders left to right

[H1] - active head - press Encoder 1 to cycle through the play heads

[N] - Normal sensitivity - press Encoder 2 to toggle between Normal and Fine
[F]

[J0] - This is level of Jitter from 0-9. Jitter controls how much the loop moves each time it restarts. From 0, no movement, to 9, maximum movement.

[1.0x] - This is the current playback speed for the active head. Turn the Encoder 4 to change the speed. Press Encoder 4 to toggle between adjusting speed/pitch as a ratio, and adjusting pitch in semitones.

The > > represent the current loop area. This is the sub-loop of audio being played by the active head. It can range from the entire recorded loop, to a tiny granular size portion. When a loop is playing you will see a line moving across the loop, this is the position of the playhead.

If you look closely at the centre of the waveform you will see a single dot moving across the centre, this is the position of the write head. The write head is where overdubs will start recording.



Menus

Using the menu button you can cycle through each of the menus until you get back to the main screen. To jump back to the main screen without cycling through the remaining menus you can hold down the menu button for 1 second.

Each menu contains 4 options which are modified using the 4 encoders. Dials and text selection boxes are changed by rotating the pots, check boxes are toggled by pressing the encoder.

Effects 1

TIME - Delay time of the delay effect - from 5 milliseconds to 0.5 seconds

FEED - Delay feedback

MIX - Mix of delay

RVB - Level of reverb



Effects 2

TAPE - Level of a broken tape effect. A wow and flutter of randomly changing frequencies change the pitch of head 0 only.

DEGR - **TO DO**

BCDE - Bit Crush - bit depth from 1 bit to 16 bit

BCRA - Bit Crush - sample rate divider

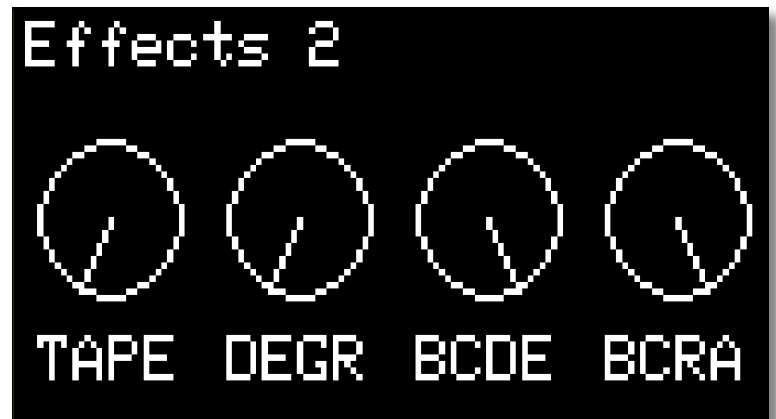

Effects 3

IN A - The volume of the incoming audio sent to Output A

IN B - The volume of the incoming audio sent to Output B

EFF - Select whether the effects are

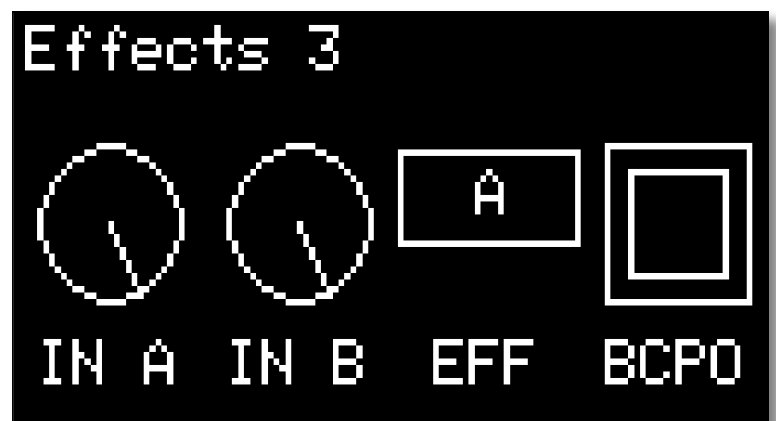

applied to Output A or Output B - rotate the encoder to select

BCPO - If enabled bit crush is applied after the reverb, if not enabled, bit crush is applied before. This allows you to choose from bit crushing the reverb tails to make them sizzle, or soften the bit crush by applying reverb to it - press the encoder to toggle

Outputs

Each play head can be sent to output A or output B, or to both outputs. On this page you can set the output for each play head, A, B or A+B. Rotate the encoder to select.

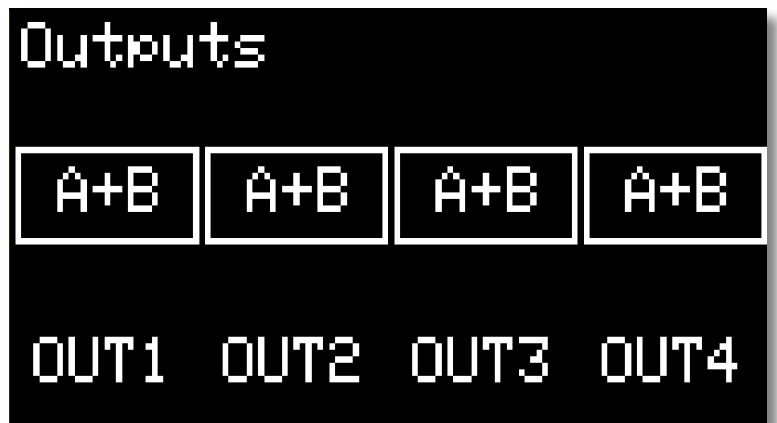

CV Targets

Each of the 4 CV inputs can be assigned to modulate one of a set of parameters. Rotate the encoder to select.

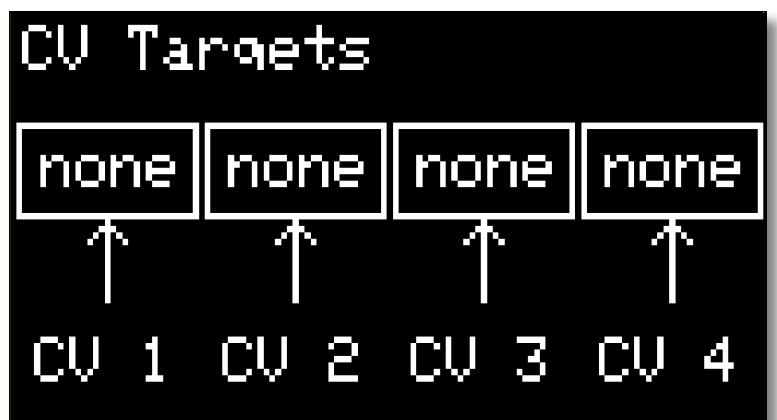

Modulation Target	Description
vol1-vol4	Volume of head 1-4
volA	Volume of ALL heads
spd1-spd4	Speed of head 1-4
spdA	Speed of ALL heads
pos1-pos4	Position (centre) of head 1-4
posA	Position (centre) of ALL heads

size1-size4	Size of head 1-4
sizeA	Adjust size of ALL heads
stl1-stl4	Start loop of head 1-4 - This expects a trigger pulse, when triggered the selected head will snap to the beginning of the loop. Play back will then loop as normal.
stlA	Start loop of ALL heads
sto1-sto4	One shot triggering of selected head - Loop will play once, when triggered, then playback will stop
stoA	One shot trigger ALL heads
jmp1-jmp4	Every time the voltage of this CV changes, jump the selected play head to a quantised position in the loop based on the positive voltage

CV Attenuation

Each dial corresponds to the attenuation of CV 1-4. Attenuating from max (original input level), to min, CV is completely zeroed. Bear in mind this attenuation is digital, and CV above +/-5V will be clipped before it gets to the module.

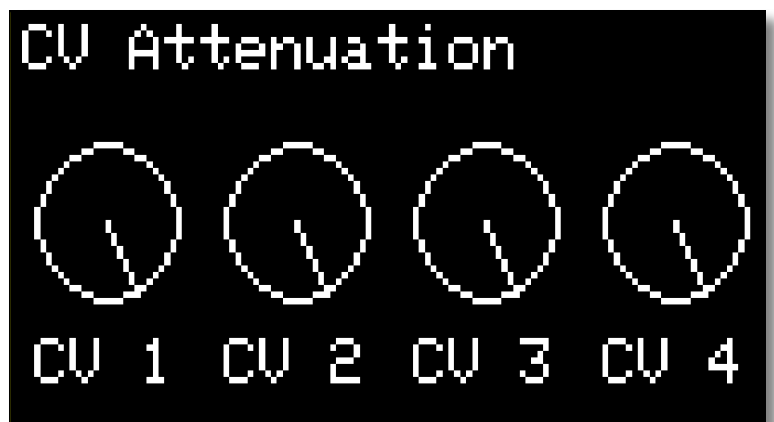

CV Misc

OFFS - This will offset all CV inputs. This is used to turn a 0V-5V DC input CV into an AC signal (centred on 0). Useful if you want to modulate something up and down but only have a positive modulation source.

OVDB - Enable or disable Overdub. Sometimes it's useful to disable overdub if you are using the trigger to start/stop recording, and want to ignore subsequent triggers after the initial loop is recorded.

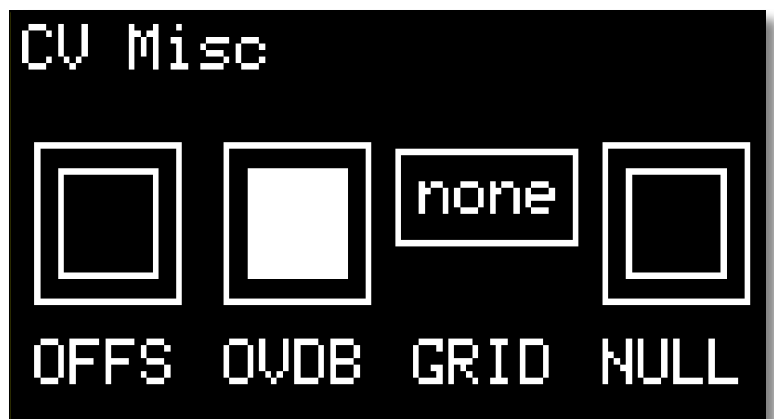

GRID - Enables the grid, at 4, 8 or 16 regions. With grid enabled all loop positions and sizes are clamped\quantised to the grid. Works great with rhythmic loops. Grid is displayed on main screen.

NULL - Currently unused.

When setting playback speed using CV

1. If you want V/Oct, you must be in Semitone view, and should have CV attenuation set to no attenuation (fully clockwise).
2. If you are in ratio view (i.e. not Semitone), the CV modulation is **not** scaled to V/Oct, it's just intended as a way to modulate speed (for warping the sound). Maximum CV results in maximum speed adjustment (x10).

Updating Firmware

To update Gloop firmware, you need a USB micro-B cable and a firmware .bin file, follow these steps

1. Connect the Daisy Seed to your PC/Mac using the micro-B cable
2. Go to <https://electro-smith.github.io/Programmer/> using Chrome
3. Hold the BOOT button down on the Daisy Seed, and then press and release the RESET button (this allows the Seed to be programmed via USB)
4. Click the Connect button
5. Select "DFU in FS mode"
6. Click "Choose File" and browse to the firmware .bin you want to update Gloop to
7. Click the Program button